



## Round Analogue Secondary Clocks in ALUMINUM



Westerstrand analogue secondary clocks are controlled and run by **24VDC polarised impulses** which are transmitted from a Westerstrand master clock/master clock programmer or time central. The impulses are 1/1-minute. The 1/1 minute impulse means that the master clock or time central synchronizes the connected slave clock once **per minute**.

### Technical information

The clocks are connected in parallel to the master clock or time central with 2-wired cable. On installation, actual time displayed on the connected clocks is set by programming the master clock or time central. The master clock or Time Central will then automatically send rapid impulses to set correct time on the installed clocks. In case of a power failure, connected clocks stop, but when the power returns they restart and are automatically corrected via rapid impulses.

### Technical data

Power supply:	Secondary Clocks to be operated by 24VDC polarized reversing 1/1-minute impulses from Westerstrand Master Clock or Time Central.
Sizes:	Dia. 600mm.
Housing:	Aluminum, powder coated in RAL 850-M.
Dial face:	White dial with either black numerals 1-12 (A-dial) or with black hour marks (H-dial).
Illumination:	Not available
Hands:	Black hours- and minute hand.
Protection:	Flat protection glass of polycarbonate, 4mm.
Mounting:	Single sided for surface wall mounting, with or without backside. Without backside only for indoor use
IP rating:	IP20 without backside and IP23 with backside
CE-approval EMC	Emission: EN 50121-4:2016, EN 61000-6-3:2007 Immunity: EN 50121-4:2016, EN 61000-6-2:2005, EN 61000-4-2, -3, -4, -5, -6, -11

## Dimension

Without backside

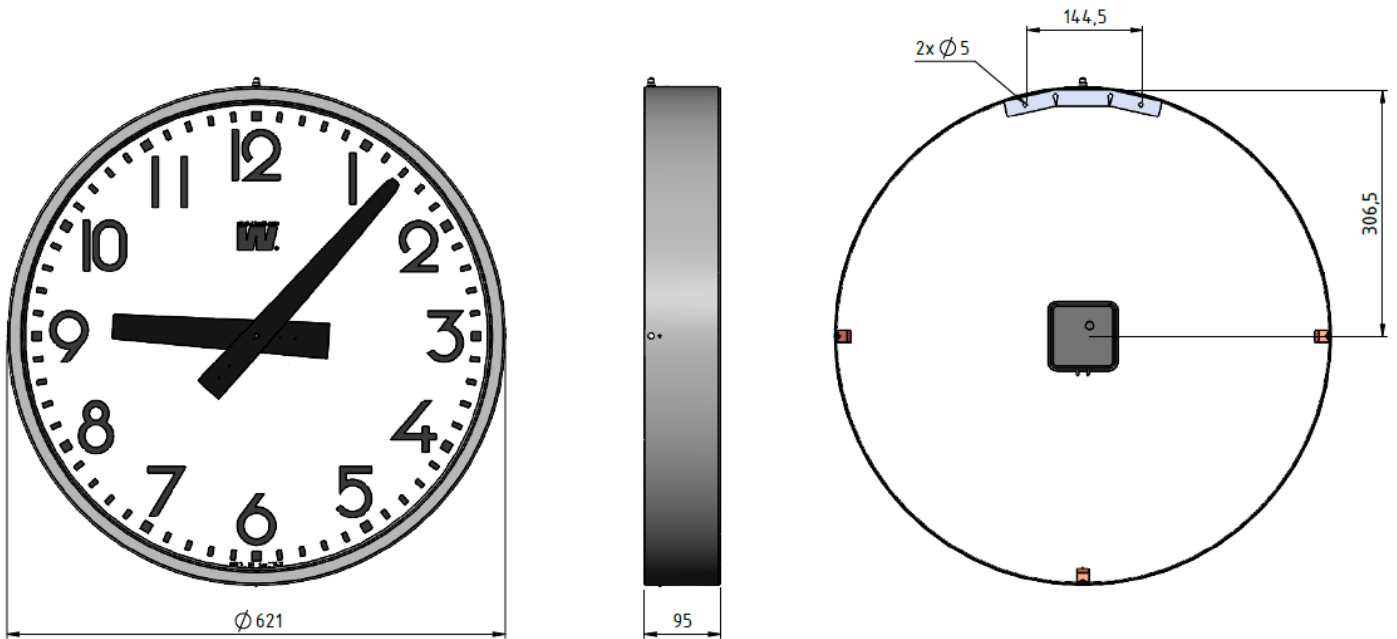

With backside

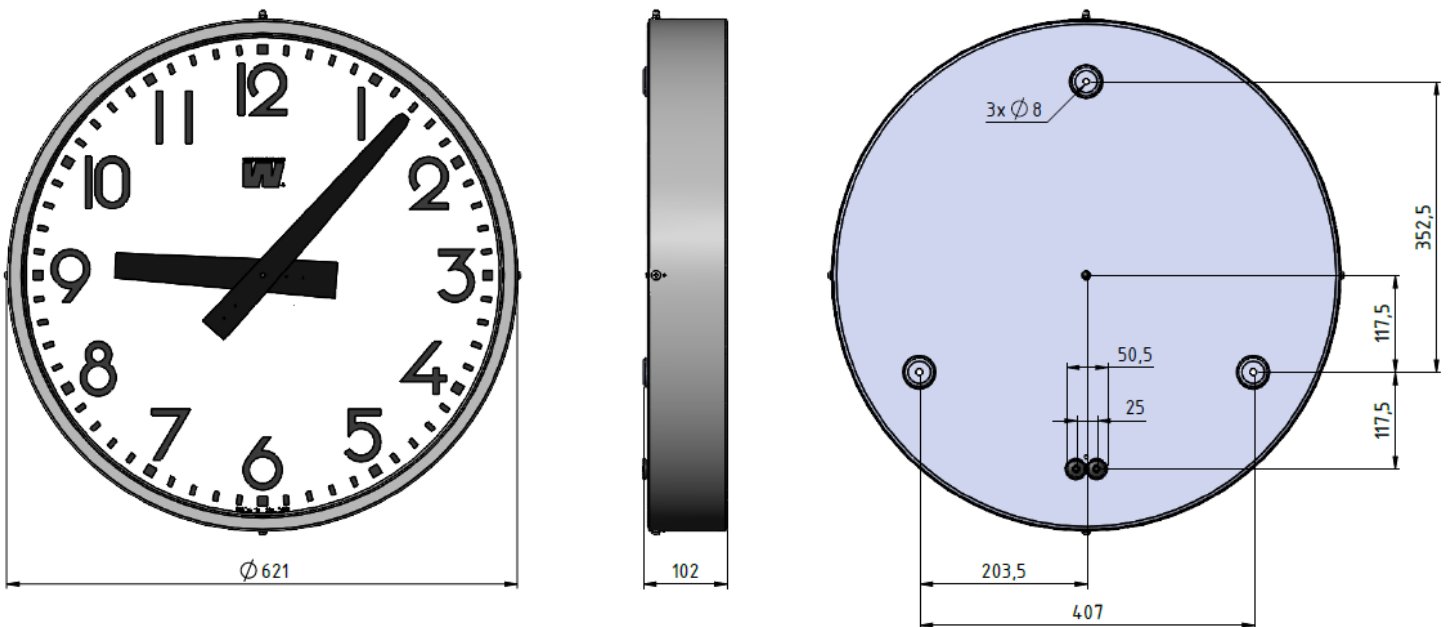

We reserve the right to make changes at any time

E486A

**WESTERSTRAND URFABRIK AB Sweden**

P.O. Box 133, SE-545 23 TÖREBODA  
E-mail: [info@westerstrand.se](mailto:info@westerstrand.se)

Tel. +46 506 480 00 Fax +46 506 48051  
Internet: [www.westerstrand.se](http://www.westerstrand.se)